

CYCLOPS
LIGHTING

LEDE 300S

300 watts LED Spot moving head

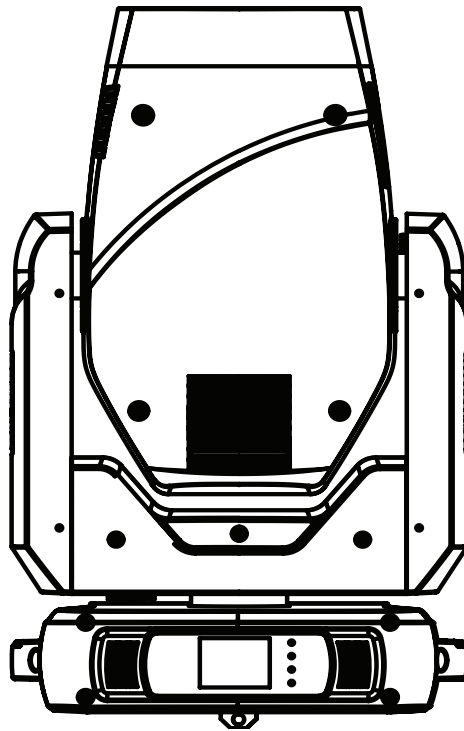

USER MANUAL

Table of contents

Caution!	3
Introduction	3
Safety instructions	3
Fixture overview	3
Installation	4
Read 'Safety information' before installing the fixture.....	4
Fastening the fixture to a flat surface	4
Mounting the fixture on a truss.....	4
Securing with a safety cable.....	5
DMX-512 connection/connection between fixtures	5
Operation	6
Addressing.....	6
Universal DMX Control	6
RDM control.....	6
Stand-alone Mode.....	6
Master-Slave Operation.....	7
Control Menu Map	7
DMX Protocol	8
Fixture Cleaning	11
Fuse Replacement	12
Troubleshooting	12
The fixture does not work, no light	12
Specifications	13

Caution!

- Be careful with your operations. With a dangerous voltage you can suffer a dangerous electric shock when touching the wires!
- Avoid looking directly into the light source!
- Indoor use only, keep this device away from rain and moisture!
- Make sure it is grounded when using it!
- Unplug mains lead before opening the housing!
- For your own safety, please read this user manual carefully before you initial start-up.
- Every person involved with the installation, operation and maintenance of this device has to
 - be qualified
 - follow the instructions of this manual
 - consider this manual to be part of the total product
 - keep this manual for the entire service life of the product
 - pass this manual on to every further owner or user of the product
 - download the latest version of the user manual from the Internet

Introduction

Thank you for having chosen LEDE 300S. You will see you acquired a powerful and versatile device. Unpack your item. Before you initial start-up, please make sure that there is no damage caused by transportation. Should there be any, consult your dealer and do not use the device.

Safety instructions

This fixture is an extremely sophisticated piece of electronic equipment. To guarantee a smooth operation, it is important to follow the guidelines in this manual. The manufacturer of this device will not accept responsibility for damages resulting from the misuse of this fixture due to the disregard of the information printed in this manual.

This device has left our premises in absolutely perfect condition. Always disconnect from the mains, when the device is not in use or before cleaning it. Keep away children and amateurs from the device! There are no serviceable parts inside the device. Maintenance and service operations are only to be carried out by authorized dealers.

Fixture overview

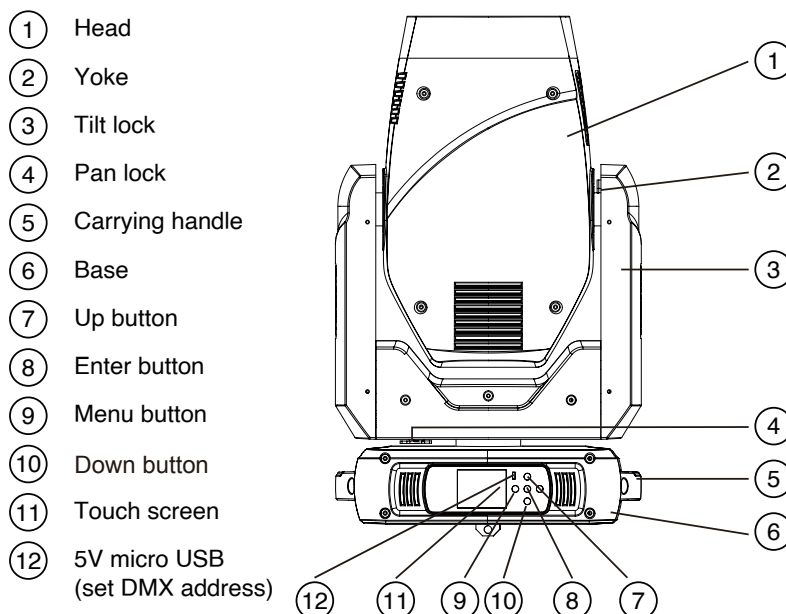

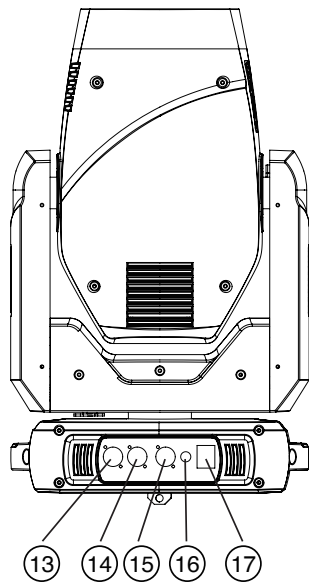

- ⑬ 3-pin DMX input socket
- ⑭ 3-pin DMX output socket
- ⑮ Powercon in
- ⑯ Fuse
- ⑰ On/Off switch

The head should be locked for transportation- the tilt lock latch (3) and the pan lock latch (4) have to be in the locked positions. To unlock the head, move these latches to unlock positions before operating the fixture.

5V micro USB port enable user to adjust fixtures' DMX address without connecting to the main power. The screen will be lit up when connected to the power bank(and not connected to main power).

Installation

Read 'Safety information' before installing the fixture

The fixture is designed for indoor use only and must be used in a dry location with adequate ventilation. Ensure that none of the fixture's ventilation slots are blocked.

Fasten the fixture to a secure structure or surface. Do not stand it on a surface or leave it where it can be moved or fall over. If you install the fixture in a location where it may cause injury or damage if it falls, secure it as directed in this user manual using a securely anchored safety cable that will hold the fixture if the primary fastening method fails.

Fastening the fixture to a flat surface

The fixture can be fastened to a hard, fixed, flat surface that is oriented at any angle. Ensure that the surface and all fasteners used can support at least 10 times the weight of all fixtures and equipment to be installed on it.

Fasten the fixture securely. Do not stand it on a surface or leave it where it can be moved or fall over. If you install the fixture in a location where it may cause injury or damage if it falls, secure it as directed below with a securely anchored safety cable that will hold the fixture if the primary fastening method fails.

Mounting the fixture on a truss

The fixture can be clamped to a truss or similar rigging structure in any orientation. When installing the fixture hanging vertically down, you can use an open-type clamp such as a G-clamp. When installing in any other orientation, you must use a half-coupler clamp that completely encircles the truss chord.

To clamp the fixture to a truss:

1. Check that the rigging structure can support at least 10 times the weight of all fixtures and equipment to be installed on it.
2. Block access under the work area.
3. Fold the legs of the mounting bracket together and bolt a rigging clamp securely to the mounting bracket. The bolt used must be M12. It must pass through both mounting bracket legs and be

fastened with a self-locking nut.

- Working from a stable platform, hang the fixture with its clamp on the truss and fasten the clamp securely.
- Secure the fixture with a safety cable as directed below.

Securing with a safety cable

Secure the fixture with a safety cable (or other secondary attachment) that is approved for the weight of the fixture so that the safety cable will hold the fixture if a primary attachment fails.

Loop the safety cable through the eyebolt in the back of the fixture and around a secure anchoring point. Do not loop the safety cable around the fixture's mounting bracket only, as this will leave the fixture unsecured if it separates from the bracket.

DMX-512 connection/connection between fixtures

Occupation of the XLR-connection:

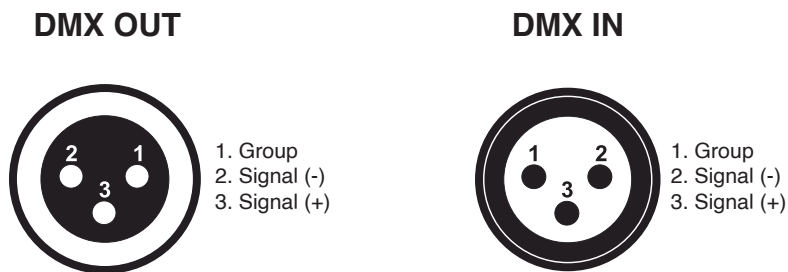

If you are using controllers with this occupation, you can connect the DMX-output of the controller directly with the DMX-input of the first fixture in the DMX-chain. If you wish to connect DMX-controllers with other XLR-outputs, you need to use adapter-cables.

Building a serial DMX-chain:

Connect the DMX-output of the first fixture in the DMX-chain with the DMX-input of the next fixture. Always connect one output with the input of the next fixture until all fixtures are connected.

DMX-512 connection with DMX terminator:

For installations where the DMX cable has to run a long distance or is in an electrically noisy environment, such as in a discotheque, it is recommended to use a DMX terminator. This helps in preventing corruption of the digital control signal by electrical noise. The DMX terminator is simply an XLR plug with a 120 resistor connected between pins 2 and 3, which is then plugged into the output XLR socket of the last fixture in the chain.

Caution: At the last fixture, the DMX-cable has to be terminated with a terminator. Solder a 120 resistor between Signal (-) and Signal (+) into a 3-pin XLR-plug and plug it in the DMX-output of the last fixture.

Connection with the mains:

The LEDE 300S is equipped with auto-switching power supply that automatically adjusts to any 50-60Hz AC power source from 100-240 Volts.

This fixture must be earthed. To use the fixture, a plug must be fixed.

The correct assembly of a sufficient plug may be done by professional persons only.

The conductors in the cable are marked by the following table.

Connect the device to the mains with the enclosed power supply cable.

Operation

The LEDE 300S can operate in three different modes. In each mode you can run the fixture as a stand alone fixture or in a master/slave configuration. This next section will detail the differences in the operating modes.

Addressing

All fixtures should be given a DMX starting address when using a DMX signal, so that the correct fixture responds to the correct control signals. This digital starting address is the channel number from which the fixture starts to listen to the digital control information sent out from the DMX controller. The allocation of this starting address is achieved by setting the correct number on the display located on the base of the device.

You can set the same starting address for all fixtures or a group of fixtures, or make different address for each fixture individually.

If you set the same address, all the units will start to listen to the same control signal from the same channel number. In other words, changing the settings of one channel will affect all the fixtures simultaneously.

If you set a different address, each unit will start to listen to the channel number you have set, based on the quantity of control channels of the unit. That means changing the settings of one channel will affect only the selected fixture.

In the case of the LEDE 300S, which is 20/25 channels fixture. If you set, for example, the address in the 20 channel mode to channel 21, the device will use the channel 21 to 41 for control.

Universal DMX Control

This function allows you to use a universal DMX-512 controller to control the chases and patterns, dimmer and strobe. A DMX controller allows you to create unique programs tailored to your individual needs.

RDM control

The LEDE 300S RDM can communicate using RDM (Remote Device Management) in accordance with ESTA's American National Standard E1.20-2006: Entertainment Technology RDM Remote Device Management Over DMX512 Networks.

RDM is a bi-directional communications protocol for use in DMX512 control systems, it is the open standard for DMX512 device configuration and status monitoring.

The RDM protocol allows data packets to be inserted into a DMX512 data stream without affecting existing non-RDM equipment. It allows a console or dedicated RDM controller to send commands to and receive messages from specific fixtures.

With RDM function, you can set the DMX address of your fixtures remotely. This is especially useful when the device is installed in a remote area.

Each LEDE 300S has a factory set RDM UID (unique identification number).

Stand-alone Mode

In this mode, you can run internal program without a controller.

1. Press the **Setting** icon in in the touch screen.

2. Select the **Fixture Set** tab.
3. Press **Up** or **Down** button and select **Run Mode** and select **Host**.
4. The fixture will run internal programs.

Master-Slave Operation

This function will allow you to link up to 16 units together and operate without a controller. In a Master-Slave set up one unit will act as the controlling unit and the others will react to the controlling units programs. Any unit can act as a Master or as a Slave.

1. Using approved DMX data cables, daisy chain your units together via the XLR connector on the rear of the units.
2. For the Master unit press the **Setting - Fixture set - Run Mode - Host** icon in in the touch screen.
3. For the slave units press the **DMX address** icon in the touch screen. Set the DMX address to 001.
4. The slave units will now follow the Master unit.

Control Menu Map

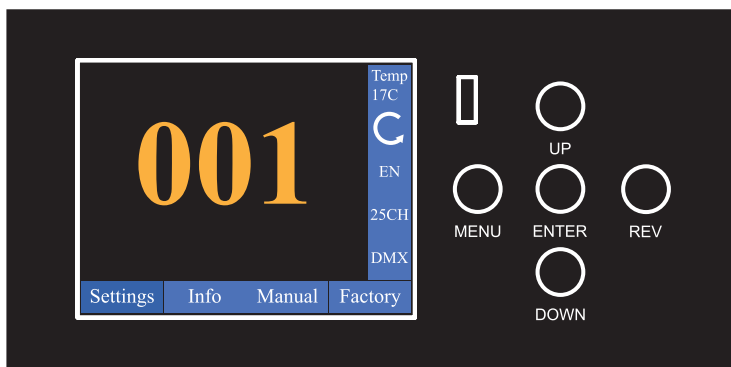

The control panel on the front of the fixture, provides access to the system menu and is where all necessary system adjustments are made to the fixture. LCD touch screen makes it very easy to navigate the system menus.

During normal operation, pressing **MENU** button once will access the fixture’s main menu.

Once in the main menu you can navigate through the different functions and access the sub-menus with the **UP**, **DOWN**, and **ENTER** buttons.

Once you reach a field that requires adjusting, press the **ENTER** button to activate that field and use the **UP** and **DOWN** buttons to adjust the field. Pressing the **ENTER** button once more will confirm your setting.

You may exit the main menu at any time without making any adjustments by pressing the **MENU** button.

The **REV** button makes it quick reverse of the LCD display.

Default settings=**bold** print

Main Menu	Level 1	Level 2	Level 3	Function
Setting	DMX address	001-512		DMX address setting
	Fixture set	DMX Mode	STD	Channel mode, standard - 25CH
			BAC	Channel mode, simplified - 20CH
		Run Mode	DMX	Control mode, DMX
			Host	Control mode, Auto program
		Pan Inverse	Close	Pan reverse movement
			Open	
	Tilt Inverse	Close	Tilt reverse movement	
		Open		
	Quiet Mode	Close	Theater mode (Fan mode)	
Open				

	Display	Language	EN	Language, English
		Display Flip	Close Open	Display Reverse 180°
		Display Mode	Show 60S	Display backlight, always on Display backlight, 60 seconds
	Reset	XY Reset	Cancel Run	Pan Tilt reset
		Moto Reset	Cancel Run	Motos reset
		All reset	Cancel Run	Reset all
		Factory	Cancel Run	Factory default
	Info	Time	Current Time	
Show Time				
Power Time				
Sensor				Sensor
Software Version	Panel		Software version	
	Moto-XY			
	Moto			
Manual	Pan	000 - 255	Manual control on board	
	Pan Fine	000 - 255		
	Tilt	000 - 255		
	...			
	Zoom	000 - 255		
	Zoom Fine	000 - 255		
Factory	Password	xxx	Advanced settings/calibration(Only qualified technicians should perform this function. Inquire your local dealer for password.)	
	Pan		Input correct password for calibration	
	Tilt			
	Iris			
	Color			
	Rot Gobo			
	Gobo Rot			
	Fix Gobo			
	Frost			
	Color 7			
	Effect			
	Prism			
	Prism Rot			
	Zoom			
Focus				

DMX Protocol

MODE/CHANNEL		DMX value	Function
STD 25	BAC 20		
1	1		Pan
		000-255	Pan movement by 540°
2	2		Pan fine
		000-255	Fine control of pan movement

3	3		Tilt
		000-255	Tilt movement by 270°
4	4		Tilt fine
		000-255	Fine control of tilt movement
5	5		Pan/Tilt speed
		000-255	Pan/Tilt speed, decreasing
6	6		Marco Function
		000-129	No function
		130-150	Pan/Tilt reset
		151-159	No function
		160-180	Effect reset
		181-189	No function
		190-210	All reset
211-255	No function		
7	7		Strobe
		000-009	Closed
		010-120	Strobe slow to fast
		121-129	Open
		130-180	Pulse strobe fast to slow
		181-189	Open
		190-240	Pulse strobe slow to fast
		241-249	Random strobe slow to fast
250-255	Open		
8	8		Dimmer
		0-255	0-100 linear dimmer
9	9		Color wheel
		0-9	Open/hole
		10-19	Color 1 (Color1+white)
		20-29	Color 2 (Color1)
		30-39	Color 3 (Color1+color2)
		40-49	Color 4 (Color2)
		50-59	Color 5 (Color3+color3)
		60-69	Color 6 (Color3)
		70-79	Color 7 (Color3+color4)
		80-89	Color 8 (Color4)
		90-99	Color 9 (Color4+color5)
		100-109	Color 10 (Color5)
		110-119	Color 11 (Color5+color6)
		120-129	Color 12 (Color6)
		130-139	Color 13 (Color6+color7)
		140-149	Color 14 (Color7)
150-159	Color 15 (Color7+white)		
160-169	Open/hole		
170-255	Forward rainbow effect from slow to fast		
10	*		Color wheel fine
		0-255	Color wheel fine
11	10		Gobo Wheel 1(Fixed gobo)
		000-009	Open/hole
		010-019	Gobo 1
		020-029	Gobo 2
		030-039	Gobo 3
		040-049	Gobo 4
		050-059	Gobo 5
		060-069	Gobo 6

		070-079	Gobo 7
		080-089	Gobo 8
		090-112	Backwards rotation from fast to slow
		113-120	Stop
		121-143	Forwards rotation from slow to fast
			Shaking gobos from slow to fast
		144-157	Gobo 1
		158-171	Gobo 2
		172-185	Gobo 3
		186-199	Gobo 4
		200-213	Gobo 5
		214-227	Gobo 6
		228-241	Gobo 7
		242-255	Gobo 8
			Animation effect wheel
		000-004	Open/hole
		005-027	Gobo 1
		028-034	Gobo 1~2
		035-056	Gobo 2
		057-063	Gobo 2~3
		064-084	Gobo 3
		085-089	Open
		090-119	Gobo 1 rotation
		120-149	Gobo 2 rotation
		150-179	Gobo 3 rotation
		180-214	Backwards rotation fast to slow
		215-220	Open
		221-255	Forwards rotation slow to fast
			Gobo Wheel 2(Rotating gobo wheel)
		000-009	Open/hole
		010-019	Gobo 1
		020-029	Gobo 2
		030-039	Gobo 3
		040-049	Gobo 4
		050-059	Gobo 5
		060-069	Gobo 6
		700-079	Gobo 7
		080-0129	Backwards rotation from fast to slow
		130-135	Stop
		136-185	Forwards rotation from slow to fast
			Shaking gobos from slow to fast
		186-195	Gobo 1
		196-205	Gobo 2
		206-215	Gobo 3
		216-225	Gobo 4
		226-235	Gobo 5
		236-245	Gobo 6
		246-255	Gobo 7
12	11		
13	12		

14	13		Rot. gobo indexing and rotation
			Gobo indexing
		0-63	Gobo indexing
		64-126	Forwards rotation from fast to slow
		127-128	Stop
		129-191	Backwards rotation from slow to fast
		192-193	Stop
		194-255	Forwards and backwards rotation from slow to fast
15	*		Rot. gobo - fine
		0-255	Fine indexing (rotation)
16	14		Prism
		0-127	Open position (hole)
		128-255	3 facet prism
17	15		Prism rotation and indexing
		000-127	Prism indexing
		128-190	Backwards rotation from fast to slow
		191-192	Stop
		193-255	Forwards rotation from slow to fast
18	*		Prism Rotation Fine
		0-255	Prism Rotation Fine
19	16		Iris
		0-134	Linear
		135-164	Fast open, Slow close
		165-194	Slow open, Fast close
		195-224	Normal Rain Effect
		225-255	Random Rain Effect
20	17		Frost
		0-127	Open/hole
		128-255	Frost
21	18	0-255	6 colors color wheel
22	19		Focus
		0-255	Continuous adjustment from far to near
23	*		Focus fine
		0-255	Fine focusing
24	20	0-255	Zoom
25	*		Zoom fine
		0-255	Fine zooming

Fixture Cleaning

Due to fog residue, smoke, and dust cleaning the internal and external optical lenses and mirror should be carried out periodically to optimize light output. Cleaning frequency depends on the environment in which the fixture operates (I.e. smoke, fog residue, dust, dew). In heavy club use we recommend cleaning on a monthly basis. Periodic cleaning will ensure longevity, and crisp output.

To clean the fixture:

1. Disconnect the fixture from power and allow it to cool for at least 10 minutes.
2. Vacuum or gently blow away dust and loose particles from the outside of the fixture with low-pressure compressed air.
3. Clean the surfaces by wiping gently with a soft, clean lint-free cloth moistened with a weak detergent solution. Do not rub glass surfaces hard: lift particles off with a soft repeated press. Dry with a soft, clean, lint-free cloth or low-pressure compressed air. Remove stuck particles with an unscented tissue or cotton swab moistened with glass cleaner or distilled water.
4. Check that the fixture is dry before reapplying power.

Fuse Replacement

This fuse is located in a fuseholder next to the MAINS OUT socket on the connections panel.

To replace a fuse:

1. Disconnect the fixture from power and allow it to cool for at least 10 minutes.
2. Unscrew the cap of the fuseholder and remove the fuse. Replace with a fuse of the same size and rating only.
3. Reinstall the fuseholder cap before reapplying power.

Troubleshooting

Listed below are a few common problems that you may encounter, with solutions.

The fixture does not work, no light

- Check the connection of power and main fuse. Be sure the external fuse has not blown.
- Measure the mains voltage on the main connector.
-

Specifications

Model	LEDE 300S
Light source:	300 watts white LED
LED life expectancy:	50,000 Hrs.
Color temperature:	6600K
	CRI 70
Beam angle:	13° to 44°
Light output:	60,000 Lux @ 2m @ 13°
	Electronic focus
Dimmer:	Linear adjustment
Color wheel:	7 colors + open
Effect color wheel:	6 colors
	Electronic variable strobe
Static gobo:	8 gobos +open
Rotating gobo:	7 gobos + open
	Gobo shake function
Animation wheel:	continuous bi-directional rotation animation wheel
Prism:	3-facet circular prism
	Iris
	Frost filter
Control protocols:	DMX, Auto Run, Master-Slave
Control channels:	20, 25 CHs
Pan:	540°
Tilt:	270°
Resolution:	16 bit
Input voltage:	100-240V/50-60Hz
Power consumption:	300 watts
DMX connections:	3 pin XLR In/Out male and female
Power connections:	PowerCon In
Dimensions:	369 x 292 x 599mm
Net weight:	18.6 Kg
Housing:	Plastic
Color:	Black
IP rating:	20