

PROJEKTA 250-RGBAL is a 250 watts RGBAL image projector. It has a superior optical system, and uniform light spot. Equipped with intelligent electronic zoom system from 15°-30° linearly adjusted. Waterproof IP 65 rating designed all indoor and outdoor professional performance venues.

SOURCE Light source: 250 watts RGBAL

OPTICAL SYSTEM Optics: 15°-30° Electronic Zoom
Light output: 90,000Lux @1m @15°

CONTROL & PROGRAMMING Rotating Gobo: 1 bi-directional Rotation
Focus: Motorized linear focus
Display: On Board Control
0-25 Hz Strobe
Control Protocols: DMX, RDM
Dimmer: 0-100% 16 Bit
Control Channel: Simple (5CHs), Mode 16 BIT (8CHs)
Color Mixing : RGBAL

ELECTRICAL Input Voltage: AC100-240V
Max Power: 300 W
Power Factor: >0.6

CONNECTIONS Power connections: 3m cable (input only)
Data connection: 3m cable (input + output)

PHYSICAL Dimensions 648 x 344 x 273 mm
Net Weight: 15 kg
Color: Off-White (Gray, Black optional)
Housing: Die-cast aluminum
IP Rating: IP66
Operation temperature: - 20°C~45°C

Dimensions

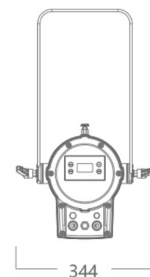
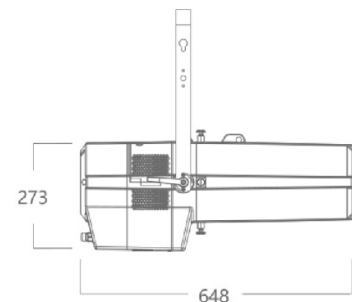

Luminous Diagram

