

CYCLOPS
LIGHTING

SPK-2

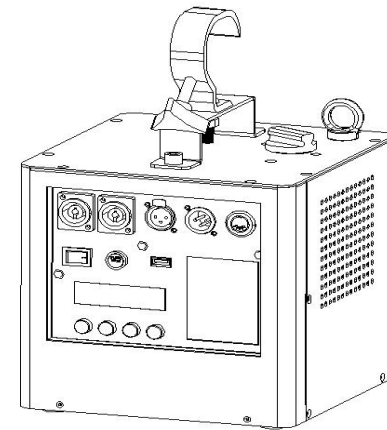

USER MANUAL

List

I .Pre-use instructions for products.....	1
II.Product description.....	2
III.Machine parameter and controller instruction.....	3
IV.Operational details and instructions.....	4
V.Product warranty instructions.....	8

4.8 installation

All low qualified personnel to install equipment and comply with EN60598-2-17 and any other electrical equipment specifications.

Load structure must be able to withstand 10 times the weight of the machine for 1 hour without distortion.

Do not stand directly under the machine when it is installed, moved or used. Allow qualified technicians to inspect the equipment once a year and before each delivery for maintenance.

Installation without pedestrians, where unauthorized personnel are unacceptable. The required angle is adjusted by installing the bracket and tightening the nut of the bracket.

Ensure that there is no flammable material within the radius of 50CM of the machine. Connect the device to the power supply with a power plug.

Installation of the machine before use must be approved by professionals.

5.Warranty Instructions

◆Warranty period: one year(the date of purchase)

◆IF the buyers do not use the same supplier's powder,the machine warranty period will be 3 month. The buyer will pay for the expenses if there are any components changes.

◆In such In the following cases, the product will not be guaranteed:

A: the product has been incorrectly operated and used inadvertently, for example, over load, over pressure, and firing;

B: the product was broken because of careless handling;

C: Problems caused by improper use of environmental factors, such as humidity, voltage instability, etc;

D: products have been modified by non factory personnel.

◆products comply with the warranty provisions, the factory will not charge maintenance fees and accessories costs, for more than the warranty period of the product, only the corresponding parts, finished goods costs.

◆the contents of this warranty card, the company has the right to interpret, if the user is unknown, please contact the local distributors.

◆not covered by the warranty include: packing box, packaging, product shell and hanger, remote control transmitter battery.

1.Pre-use instructions for products.

Thanks for your choosing our SPK-2 .We recommend that you carefully read these operating instructions before commissioning the unit. Please follow the instructions in this manual. This is the only way to ensure safe operation, proper use and long service life.

1.1 Safety Instruction

>A qualified technician should install and service this device.

>Be very careful during the installation: touching live wires can cause life-threatening electric shocks.

>Keep this device in a dry area at all times

>Disconnect all power before opening the housing for any reason

>Keep the device away from children and unauthorized users

>Damage caused from not following the guidelines in this manual are not covered by the warranty and the we will not accept responsibility for any resulting defects or problems

>Make sure that the available voltage does not exceed the voltage stated in the specification section of this manual.

> This device falls under protection class 1. It is essential that the device be earth grounded. Do not remove or isolate the grounding pin.

>The device housing will be very hot, do not touch when working, and have it rest every working two hours

>Disconnect the device from all power to clean it or when it is not in use . Handle the power cord by the plug only.

>Note the damage caused by user modification to the device is not covered by the product warranty.

>Do not switch the device on immediately after it has been exposed to extreme changes in temperature. Protect the device against damage by leaving it switched off until it has reached room temperature.

>Do not touch the device during operation as the housing heats up.

1.2 Important environmental information about this product.

> Do not dispose of the unit (or components) as unsorted municipal waste; it should be taken to a specialized company for recycling.

>This device can be returned to your distributor or to a local recycling center..

>Respect local environmental rules and the environment.

>If in doubt, contact your local waste disposal authorities.

>Thank you for choosing our products. If the device was damaged in transit, don't operate or install the unit and contact your dealer.

1.3 General Guidelines

- > This device is designed for professional use on the stages, clubs, theaters, etc. The device should only be used indoors with a AC 220V/50Hz power supply.
- > Do not shake the device. Use care when installing or operating the device.
- > Select a service location where the device is protected against extreme heat, dust and moisture.
- > Familiarize yourself with the functions of the device before actually using it. Do not allow operation by unqualified people. Any damage to the unit would likely be due to unprofessional use of the device.
- > Use the original packaging or an appropriate case if the device is to be transported.
- > All modifications of the device are prohibited for safety reasons and will void the warranty.
- > Only use the device for its intended purpose. All other users may lead to short circuits, burns, electric shocks, crash, etc. Using the device in an unauthorized way will void the warranty.
- > Disconnect the device from all power to clean it or when it is not in use. Handle the power cord by the plug only
- > This device is not designed for permanent operation. Excessive usage may reduce the life span of your smoke machine.

2. Description of the product

2.1 features:

- ※ eco-friendly, safety, no gun powder.
- ※ Support wireless control, LCD and DMX, easy to operate.

2.2 Maintenance precautions:

- ※ Please clean the sparking machine regularly, that will reduce the replacement frequency and repair cost of spare parts.
- ※ If you don't use it for a long time, clean up the machine's powder and seal it up.
- ※ The sparking machine should use our EWAY powder, which can prolong the life of the machine!
- ※ Please keep the remote control parts of sparking machine, if lost, our factory will not provide accessories freely!
- ※ Our sparking machine accessories are not suitable for other brands of sparking machine, otherwise it will burn out!

4.6 Important Operational instructions!

1. This machine can be put vertical only, not sideways, flat.
2. Add powder and TIGHTEN the cap
3. NEVER POUR SPARK POWDER INTO THE SPARK DISCHARGE OPENING! THIS CAN BE DANGEROUS! SPARK POWDER MUST ONLY BE ADDED TO THE STORAGE TANK THAT REQUIRES THE REMOVAL OF THE PROTECTIVE CAP. DO NOT OVERFILL! AFTER FILLING REPLACE CAP AND TIGHTEN.
4. Please do not test the spark for a long time, which will reduce the use time of the machine sparking.
5. After each time use before shipped, please clear granules from storage tank, allow machine to cool, then remove tank cap and invert machine to shake granules out of tank.
6. The powder should not be exposed to the air. If a bag of powder is not used up, it should be kept in a sealed condition and not exposed to open fire. Store or dispose of properly!
7. Damages caused by the disregard of this user manual are not subject to warranty. The dealer will not accept liability for any consequent secondary failures. Only skilled workers are allowed to carry out the electrical connections.
- 8: ONLY INDOOR POWDER CAN BE USED FOR THIS MACHINE
- 9: AS special upside down spark, please keep a safety distance - we suggest at least 5meter under the sparking

4.7 RFID card

◆ Why we have to use safety card before use ?

To avoid damage to the machine caused by powders not suitable for the machine. PLEASE USE EWTX POWDER ONLY!

To avoid the accident that may cause by unauthorized person or children by mistake. Please keep the card for the right person only.

◆ Where you can find the card and How to use it ?

The safety card is packaged together with our powders, Each bag of powder should have one card.

Tap the Card to the Induction zone to activate the device. Each card enables the unit to work 20 minutes (that's almost the using time for one bag powder). In the meantime, the card will be invalid after being read one time.

◆ How to check the remaining time ?

Press "Menu" buttons till the page "Time" to check the remaining time (second) of using. Tap another new card to re-activate the unit when the time is over.

4.4 :Connection to the mains

Connect the device to the mains with the power plug .The jack POWER OUT allows for power supply of further devices .To interconnect several devices ,connect the jack POWER OUT to the input POWER IN of the next unit all units are connected .Matching power cables with P-Con plugs are available as accessories.IN this manner, up to 3 devices can be linked

4.5 Notes before use :

1. Place the sparking machine **vertically**, and inspect for damaged at each use . If damaged, please contact us for service. Unscrew the lid of powder tank to pour in the our powder, and then lightly tighten the lid.
2. Before power on, please verify that the supply voltage is in conformity with the rated voltage of the sparking machine. At power on, the machine will begin to heat for use .Connect the machine to your selected controller.
- 3.The machine must be used only in a well ventilated place but not where is air flow if limited or the machine’s thermal protection system may cause a shutdown.
4. The sparking machine can be used on the vertically only. The machine should have 50CM clearance all around. Keep away from children, flames, flammable and explosive materials. Keep a minimum of **5M away from the output nozzle** to prevent scalding.
5. Do not allow machine to run out of powder. If the machine is allowed to run empty,it may cause the motor and heater to be damaged ,Turn off the power before adding powder and do not allow powder to enter the inside of the housing ,as internal electrical damage may result.
- 6.If spark output is low ,or there is noise from motor,or the machine stops creating spark altogether.Do not modify or repair the machine by yourself.please contact the dealer.

2.3 Appearance of the machine:

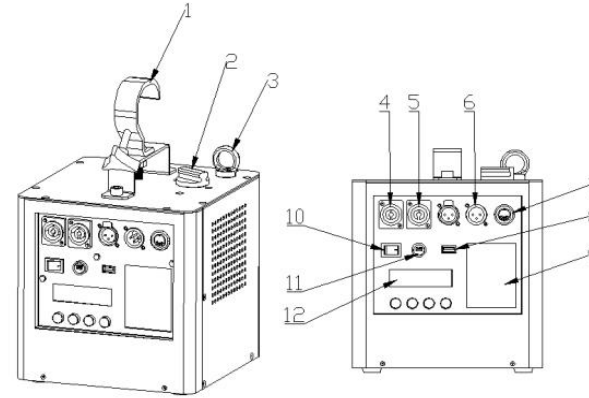

1	2	3	4	5	6	7
Hang hook	Powder entrance	Safety Loop	Power out	Power in	DMX-512	Cable control
8	9	10	11	12		
USB	Image	on/off switch	Fuse	Display board		

2.4: Specification:

Rated voltage	AC220V/50Hz/AC120V/60Hz
Rated power	500 W
fuse	10 A 5 A
Pre-heating time	<8 min
Spark max height	2-7m
Spark height change	support
Wireless controller	W-8
Display screen	LCD display board
DMX	support
DMX channel	2
DMX range	1-512
Net weight	7.4 Kg
Gross weight	8.2Kg
Machine size	205*205*220mm
Carton size	275*275*290mm

3.1: W-8+W-3 wireless controller instruction

When machine ready to spark out, the ready led will glow .There are 3 Channels(Dip 1-3) can be selected for group-1,group-2,group-3



When use remote controller: The spark height depends on the setting of Volume Out xxx% on the display screen.

Button	Function
1	Spark effect on
2	Spark effect off (keep pressed for 10 seconds to active cleaning function)
3	10 seconds spark
5	20 seconds spark.
7	30 seconds spark.
4	Sparkeffect on group1 (Receiver = 1)
6	Sparkeffect on group2 (Receiver =2)
8	Sparkeffect on group3 (Receiver =3)

4.Operational details and instructions

4.1 Basic Operational Prerequisites

1. In order to better maintain the machine,the duration of each continuous sparkling is limited to 8 minutes. Please turn off the power after sparkling 8 minute. Let the machine cool for 5 minutes before it works.
2. The height of the spark-jet part of the machine can be adjusted. In order to stabilize the machine and protect the environment.
3. When you don't use the machine for a long time, in order to keep the powder from dampness, please pour out the powder and keep it sealed for reserve.
4. When working, be sure to lock the inlet and outlet, otherwise it may cause the fire of dancing powder.

4.2 menu control panel operation:

Menu keys: you can enter menu items, press OK to enter settings, press Increase, Reduce keys to adjust settings

Content displayed	expression
【Ready To Work 】	It means that the machine is ready and can be sparkled at any time.
【Warming Up..... 】	It means that the machine is being heated.
【DMX512 Add.xxx 】	Set DMX512 address: minimum 1, maximum 512
【Volume Out xxx %】	Set the amount of sparkle: minimum 1%, maximum 100%.
【Tip Over】	Dumping alarm, setting if to alarm when the inclination is less than 45 degrees.
【Manual Test】	Manual switch sparkle, only for testing.

4.3 DMX

When using the DMX mode, two channels are occupied:

First channel	Function
0	Spark effect off
1-255	Spark effect on
Second Channel	Function
0-20	Pre-heat off, And the first channel is invalid
50-100	Pre-heat on, And the first channel is valid
150-200	Clear Materical, And the first channel is invalid

The priority relationships: DMX, Remote controller.